

metazet™

SUPPORTING YOUR GROWTH

USER MANUAL

TRIKE-400

TRIKE-1200

TRIKE-3000

E-NOVA

H-400

HT-400XL

HT-1500

Preface

General

Your product complies with all applicable safety regulations. To use your product safely, read this manual carefully and follow all instructions before using your product. This way you prevent accidents and retain the right to warranty within the set period.

This manual applies to different types of vehicles: sit-on tractors, standing tractors, walking tractors and 'load' vehicles. The bookmark on the right side of the page indicates which type of vehicle this page applies to.

A (digital) copy of this manual is supplied with each product. The manual must be stored in a place that is accessible to the user. If the manual is lost or becomes unreadable, a new version must be requested immediately.

If you have any questions or concerns after reading this manual, please contact the manufacturer.

Manufacturer

Metazet B.V.
De Lierseweg 6
2291 PD Wateringen
The Netherlands

Tel. +31 (0)174 225 822
www.metazet.com

Table of Contents

Preface	2
General	2
Manufacturer	2
1. About your product	5
1.1 General	5
Trike - 400- 1200- 3000	5
E - Nova	5
H - 400	6
HT - 400 XL / - 1500	6
1.2 Accessories	7
1.3 Where and when to use your product	7
1.5 Quality control	7
2. Safety	8
2.1 Inadmissible use	8
2.2 Use original parts only	8
2.3 Other risks	8
2.4 Safety instructions	9
2.5 Disposal of the product	9
3. Information for the company	10
3.1 User	10
3.2 Driver	10
3.3 Damage and defects	10
3.4 E.C. Declaration of Conformity	10
3.5 Copyright	10
4. Use of your product	11
4.1 Start	11
4.1.1 Power On/Off (Image 4.1)	11
4.1.2 Battery indicator	11
4.1.2.1 Battery indicator LEDs	11
4.1.2.2 Battery indicator LCD screen	12
4.1.3 Warning and safety equipment	12
4.1.4 Danger zone	12
4.1.5 Emergency button (Image 4.4)	13
4.1.6 Emergency stop (Image 4.5)	13
4.1.7 While driving	13

4.2	General product instructions for use	14
4.2.1	Steering lever	14
4.2.1.2	Driving backwards (Image 4.7)	14
4.2.1.3	Speed switch (Image 4.8)	14
4.2.1.4	Steering gear	15
4.2.1.5	Horn (Image 4.9)	15
4.2.2	Foot switch	15
4.3	Product-specific instructions for use	16
4.3.1	Trike	16
4.3.2	E-Nova	18
4.3.3	H-400	21
4.3.4	HT-400 XL	21
5.	The battery	22
6.	Battery charger	23
6.1	Charging Lead Acid Battery (XLR)	23
6.2	Charging Lithium-ion Battery (Speakon)	24
6.3	Information battery charger	25
6.3.1	LED-codes battery charger	25
6.3.2	Comments:	26
6.3.2 .1	Charging with charger	26
7.	Maintenance	27
7.1	General maintenance	27
7.1.1	Maintenance every month:	27
7.1.2	Maintenance every 3 months:	27
7.1.3	Maintenance every 6 months:	27
8.	Error codes	28
8.1	Error codes LED battery indicator	28
8.2	Error codes LCD battery indicator	29
9.	Parts & Service	30
10.	Quick manual	30
11.	Resolving problems	31
12.1	Technical specifications Trike 400	32
12.2	Technical specifications Trike 1200	34
12.3	Technical specifications Trike 3000s	36
12.4	Technical specifications E-Nova	38
12.5	Technical specifications H-400	40
12.6	Technical specifications HT-400 XL	42
12.7	Technical specifications HT-1500	44
12.8	Type plate	46

1. About your product

1.1 General

Trike - 400- 1200- 3000

The Trike is an electric standing tricycle that is primarily designed for personal transport and pulling (heavy) loads. Due to the various available couplings, a wide variety of carts, such as CC carts, can be easily moved. The Trike also offers space for a Euronorm 600x400 container in which various items and tools can be transported. The compact dimensions and short turning circle make the Trike agile and ideal for use in applications where space is limited. Thanks to the large pneumatic tires, the Trike can also be used on unpaved surfaces. The Trike is suitable for transporting a single person.



E – Nova

The E-Nova is an electric sit-down tricycle that is primarily designed for personal transport and pulling (heavy) loads. Due to the various available couplings, a wide variety of carts, such as CC carts, can be easily moved. The E-Nova also has a storage space under the seat in which various items and tools can be transported. The compact dimensions and short turning circle make the E-Nova agile and ideal for use in applications where space is limited. Due to the large pneumatic tires, the E-Nova can also be used on unpaved surfaces. The E-Nova is suitable for transporting a single person.



Trike-400

Trike-1200

Trike-3000s

E-Nova

H-400

HT-400 XL

HT-1500

H - 400

The H-400 is an electrically powered walk-along vehicle, which is primarily designed for pulling (heavy) loads.

Due to the various available couplings, a wide variety of carts, such as CC carts, can be easily moved.

The compact dimensions and short turning circle make the H-400 agile and ideal for use in applications where space is limited.



HT - 400 XL / - 1500

The HT series are electric platform vehicles that are primarily designed for moving (heavy) loads. The goods can easily be placed on the spacious platform.

The compact dimensions and short turning circle make the HT series agile and ideal for use in applications where space is limited.



HT-400 XL



HT-1500

Trike-400

Trike-1200

Trike-3000s

E-Nova

H-400

H-400 XL

HT-1500

1.2 Accessories

Your product comes with the following accessories:

- Keys for key switch
- Battery charger (including plugs)
- Quick manual
- USB stick with documentation

1.3 Where and when to use your product

Your product is suitable for both indoor and outdoor use, but conditions must be dry. The surface on which the product is used must be hardened or sufficiently firm. The driver must take into account that the type of surface influences the braking distance of the product. The product should be used in temperatures between 0°C and 45°C.

1.4 Definitions of drive direction

The driving directions forward, backward, left, right, are defined from the point of view of the driver who positions himself towards the product with the steering wheel in front of him.

1.5 Quality control

Before a product is shipped to a customer, it undergoes an extensive quality check according to a standard checklist. This way, the delivery of a correctly functioning product is guaranteed. In the unlikely event that the product does not function properly, please contact us via the service page on our website www.metazet.com

2. Safety

2.1 Inadmissible use

The user is at all times responsible for all consequences arising from the use of your product for purposes other than those prescribed. Use for purposes other than those described in this manual is prohibited. It is prohibited to use your product in areas where highly flammable or explosive materials are present. Your product may not be used on public roads and in cold stores. If you are not sure whether application or action is permitted, you can always contact the manufacturer.

2.2 Use original parts only

All parts that make up your product have been specially selected and/or designed for this application. Other parts that have not been tested and approved by the manufacturer may have a negative effect on the functionality of your product. Use of these parts is not recommended by the manufacturer and is entirely at your own risk. The manufacturer recommends using only original parts.

It is prohibited to modify, weld or make other changes to the product yourself without written permission from the manufacturer. If this is still done, the warranty on the product and liability of the manufacturer will be void.











2.3 Other risks

Your product complies with all current safety regulations. Despite all safety regulations and measures, it is impossible to exclude all risks when using the product.

Your product complies with the currently applicable guidelines. The non-excludable residual risks can be limited by being careful when driving your product. The remaining risks may include, but are not limited to:

- Risks of accidents due to use with unfavourable surfaces, such as slippery conditions, slopes, poor visibility, soft surfaces, etc.
- Human error: careless use and failure to follow the instructions in the manual.
- External risks: risks that do not directly arise from the use of your product
- Risk of accident when driving in difficult conditions, such as slopes, slippery or irregular surfaces, or due to poor visibility, etc.
- Falling, tripping, etc. when moving on the tractor, especially in wet conditions, leaking fluids or on frozen surfaces
- Loss of stability due to a shifted or unstable load, etc.
- Fire and explosion hazard due to batteries and electrical voltages
- Damage to fingers when coupling trailers or placing goods down

2.4 Safety instructions

-  Do not use your product if it poses a risk to safety and/or health.
-  If your product is damaged, do not release your product until a certified person certifies that the damage poses no risk or until the damage has been repaired.
-  If your product catches fire, call your safety authorities immediately.
-  Please note that your product will only apply engine braking when the throttle is released or the emergency brake is activated; there is no additional braking system! In the case of E-Nova: the foot brake only helps when the throttle is released.
-  First take a test drive on an open secured terrain to learn how your product works and learn the acceleration and deceleration to anticipate the braking distance.
-  Your product is not designed for transport of multiple persons.
-  Only drive at 'turtle' speed when carrying/pulling objects. Max Rijd alleen met de snelheid van de 'schildpad' bij het dragen / trekken van voorwerpen. Max towing weight, carrying load and personal weight: see technical specification of your product.
-  Make sure your product is regularly maintained to ensure safe use (*See chapter 7 'Maintenance'*).
-  Always drive your product with all wheels in contact with the ground. This prevents accidents.
-  Removing the safety barriers is not recommended unless necessary for maintenance. The electrical components beneath these barriers can be irreversibly damaged. Damage may cause electric shock.
-  If your product cannot be used safely, always turn it off. Push your product to a safe position. Always push with at least 2 people, of which 1 person takes the driving seat and steers your product.

2.5 Disposal of the product

The product must not be disposed of with normal waste. Dispose of the product in accordance with the environmentally friendly recycling regulations applicable in your region.

3. Information for the company

3.1 User

The user is the natural or legal person who used your product or on whose behalf your product is used. The user is responsible for complying with and checking the safety regulations. The user is also responsible for possessing the manual.

3.2 Driver

Your product should not be driven by persons who are not in the condition to drive a vehicle (persons with fractures, neck problems, other injuries and pregnant women). The driver must be at least 16 years old. The driver is responsible for the use of your product. The driver must be aware of his/her surroundings. The manual must always be available to the driver.

3.3 Damage and defects

All damage and defects must be reported immediately to maintenance personnel or the operator. If your product is not safe to use, it should not be used until the damage or defects have been repaired.

3.4 E.C. Declaration of Conformity

With this E.C. declaration of conformity, the manufacturer confirms that your product complies with guidelines at the time the rules of the EC machine guidelines were written. The E.C. conformity symbol was affixed to the Type Plate attached to your product. Altering the design of your product in any way may cause unacceptable health risks. In this case the E.C. declaration of conformity becomes invalid.



3.5 Copyright

This manual, or any part of this manual, may never be duplicated, translated or made accessible to third parties without the express permission of the manufacturer.

4. Use of your product

4.1 Start

Before using your product, it is necessary to familiarize yourself with the various controls.

4.1.1 Power On/Off [Image 4.1]

Insert the key in the ignition lock. Turn right to turn on your product. Turn left to turn off your product.



Image 4.1 - Key switch

4.1.2 Battery indicator

Your vehicle uses one of the battery indicators below.

4.1.2.1 Battery indicator LEDs

Check the battery indicator. If the battery indicator shows 10 LEDs (3x red, 4x orange, and 3x green), the battery of your product is full. The number of LEDs indicates the State of Charge (SOC) of the battery (the remaining capacity). For example, 6 lit LEDs means an SOC of 60%.



Image 4.2 - Battery is full

In the chapter **'The battery,'** you can read about how to best handle discharging and charging the battery pack in your product.

The battery indicator also indicates errors. When the LEDs flash, refer to the **'Error codes'** chapter.

4.1.2.2 Battery indicator LCD screen

Check the battery indicator. If the battery indicator shows 10 blocks, the battery of your product is full. The number of blocks indicates the State of Charge of the battery (the remaining capacity). For example, 8 blocks means an SOC of 80%.



Image 4.3 - Full battery

In the chapter '**The battery,**' you can read about how to best handle discharging and charging the battery pack in your product.

The battery indicator also indicates errors, through an error code on the screen. In case of an error code, refer to the '**Error codes**' chapter.

4.1.3 Warning and safety equipment

Before using your product, check that all warning and safety equipment such as the horn and steering handle mounting are working properly.

4.1.4 Danger zone

Before, but also during, the use of your product, no persons or goods may be in the danger zone. If there is a risk, the driver must warn in time. If the dangerous situation is not resolved, the driver must stop the product immediately. The danger zone is the area in which persons are at risk of harming themselves due to the movement of the product and/or load. The zone also includes the area that can be reached by falling load.

4.1.5 Emergency button [Image 4.4]

Check the emergency button before driving. The emergency button is located on the steering lever. If you press the emergency button, your product will stop and it will be impossible to continue driving. Restart your product to cancel the emergency button. (See **SWITCHING ON/OFF**)



Image 4.4 – emergency button

4.1.6 Emergency stop [Image 4.5]

Before driving, check the emergency stop. The emergency stop is located on the front of the handlebar. To resume using your product, first turn the button counterclockwise and pull it. Then restart your product to cancel the emergency stop. (See **SWITCHING ON/OFF**)

The emergency stop is used in case of an emergency.



Image 4.5 – emergency stop

4.1.7 While driving

Make sure you minimize risks while driving. This includes adjusting your speed to your environment. Make sure you always have enough space to manoeuvre the product and keep your distance from others to make a timely stop. Always ensure good visibility.

4.2 General product instructions for use

This describes the use of various controls for the functions applicable to the various products in this manual.

4.2.1 Steering lever

4.2.1.1 *Driving forward (Image 4.6)*

Push the grey switch forward with your thumbs. The speed depends on the extent to which the switch is pressed. Always be careful to prevent shocks. When the switch is released, your product will brake electrically.

WARNING: You have no direct control over the brakes. Slowdown in time to prevent accidents.

4.2.1.2 *Driving backwards (Image 4.7)*

Push the grey switch backwards with your thumbs. The speed depends on the extent to which the switch is pressed. Always be careful to prevent shocks. When the switch is released, your product will brake electrically.

WARNING: You have no direct control over the brakes. Slowdown in time to prevent accidents.



Image 4.6 – driving forward



Image 4.7 – driving backwards

4.2.1.3 *Speed switch (Image 4.8)*

Your product is equipped with a speed switch located on the steering lever. The switch has two positions, the turtle (slow) and the 'hare' (fast). Switch between the two modes by pressing the desired positions. When your product is used for carrying or pulling, use 'turtle' speed only.



Image 4.8 – speed switch

4.2.1.4 Steering gear

Your product is controlled by turning the steering wheel in the desired direction.

WARNING: Your product is not protected against sharp steering. Steer only when the turn can be executed smoothly. If your product starts to vibrate, reduce the steering angle immediately.

4.2.1.5 Horn (Image 4.9)

The horn is used by pressing the horn button.



Image 4.9 – horn

4.2.2 Foot switch

Some products are equipped with a foot switch. The foot switch is a switch applied to the product where the presence and attention of the operator is essential for safety. To use the product, the user must press the foot switch. As soon as the foot switch is no longer operated, the product will automatically stop.

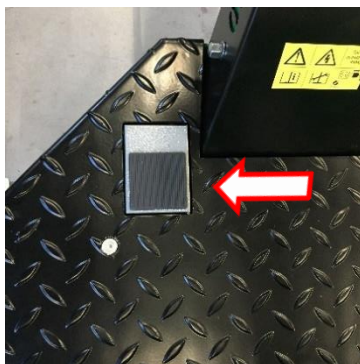

Image 4.10

4.3 Product-specific instructions for use

4.3.1 Trike

4.3.1.1 Unlocking the electric braking system (Image 4.11-4.12)

The electric parking brake system is automatically activated. Pull the lever at the back of your product (red from 2024) to the right and then downwards to deactivate and lock it. To reactivate the braking system, push the lever back in the opposite direction. Unlocking the brake system is only used in case of issues with your product.

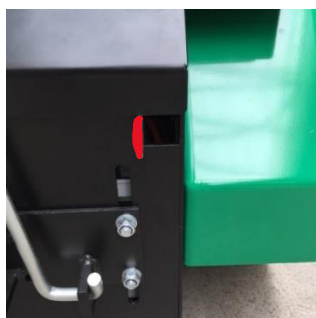

Image 4.11



Image 4.12

4.3.1.2 Attaching the box (Image 4.13 -4.14)

Place the box under the extended edge. Secure the box with the screw.



Image 4.13 – placing box



Image 4.14 – securing box

4.3.1.3 Adjusting the backrest (Image 4.15 en 4.16)

Adjust the height of the backrest by loosening the bottom bolt of the clamp. You can then slide the back support over the tube and tighten the bolt again at the desired height.



Image 4.15 – backrest



Image 4.16 – the clamp of the backrest

4.3.1.4 Accuslede Trike 3000s (Afbeelding 4.17)

The Trike-3000s is equipped with a replaceable battery pack. It is possible to ride this sled out of the Trike 3000s. This is only possible when the Trike 3000s is switched off. To disconnect and exchange the battery cradle, follow these steps:

1. Place a drive-out platform behind the Trike 3000s, ensure that it is aligned at the same height as the battery pack in the Trike and switch off the Trike 3000s!
2. Release the lock by pulling the grey T-handle. (Figure 4.17.1)
3. Partially remove the battery pack from the Trike 3000s and release the safety catch. (Image 4.17.2-4.17.3)
4. Remove the battery pack completely and exchange it for a new pack, making sure it is positioned in the middle. (Figure 4.17.4)
5. Drive the new battery pack partially through so that the fall protection can be reattached. (Figure 4.17.5)
6. Push the new battery pack fully into the Trike.
7. Secure the carriage again by pressing the grey T-handle. (Figure 4.17.6)
8. Before putting the Trike 3000s back into use, check whether the T-handle is fully pressed in. This means that only the green ring will be visible.



Image 4.17.1



Image 4.17.2



Image 4.17.3

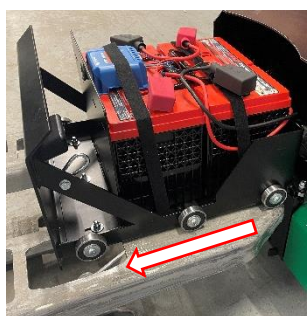

Image 4.17.4

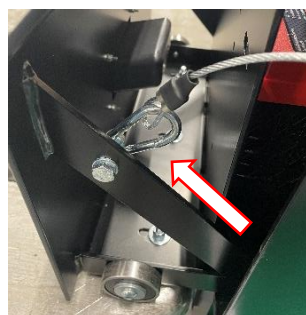

Image 4.17.5



Image 4.17.6

4.3.2 E-Nova

4.3.2.1 Foot brake (Image 4.18)

The E-Nova brakes automatically when the switch is released. A foot brake has been placed on the right side of the platform to brake even faster. When you press this with your right foot, the drum brakes on the rear wheels are activated.



Image 4.18 – foot brake

4.3.2.2 Unlocking the electronic braking system (Image 4.19 – 4.20)

The electric parking brake system is automatically activated. Pull the lever to the left to deactivate the system. To reactivate the braking system, push the lever back to the right. Unlocking the brake system is only used in case of issues with your product.



Image 4.19



Image 4.20

4.3.2.3 Unlocking the electric braking system electrically (Image 4.21)

The electric parking brake system is automatically activated. By pressing a button on the right rear of your product, you can electronically unlock the braking system. You can only do this when your product is powered on. Unlocking the braking system is used when attaching a trailer behind your product.



Image 4.21

4.3.2.4 Move chair (Image 4.22- 4.23)

The seat of the E-Nova can be moved forwards and backwards for optimal adjustment. Moving the seat works as follows: Sit on the seat and pull the lever on your right. As you pull that lever out you have the option to shift forward and backward.



Image 4.22



Image 4.23

4.3.2.5 Storage space (Image 4.24- 4.25)

The storage space is located under the white cover to which the chair is attached. This is unlocked by turning the key a quarter turn and pulling out the unlock button. By pushing the cover up at the rear, the cover opens. Closing is done in reverse order.



Image 4.24



Image 4.25

4.3.2.6 Change battery pack (option) (Image 4.26 – 4.28)

The replaceable battery pack is located on the left side of the E-Nova.

1. **Switch off the E-Nova first**
2. Open the white cover (Image 4.25) to remove the cover to the plug. The cover is secured with 2 star bolts (Image 4.26) and must be loosened. After these have been loosened, the cover can be removed and the plug can be disconnected.
3. With the plug disconnected (Image 4.27), lift the battery pack (Image 4.28) slightly and pull it toward you. The new battery pack is replaced in reverse order.

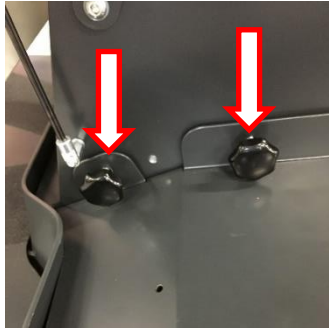

Image 4.26

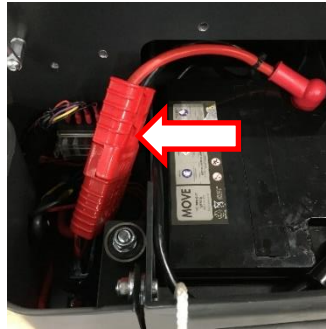

Image 4.27



Image4.28

4.3.3 H-400

4.3.3.1 Adjustable steering angle (Image 4.29)

The steering angle of the H(T)-400 is adjustable. To adjust the steering angle to the correct height, you must unlock the locking pin.



Image 4.29

4.3.3.2 Operation of electric gripper (option) (Image 4.30)

You can operate the electric gripper using the arrow switch. By using the switch, you can open and close the gripper on your product.



Image 4.30

4.3.4 HT-400 XL

4.3.4.1 Open standing platform (option) (Image 4.31-4.32)

The HT-400 XL can be equipped with a standing platform, enabling easy and comfortable maneuvering with your HT-400 XL. You can easily open this standing platform by pulling the pin and folding the standing platform down. You close it by folding the standing platform back up.



Image 4.31



Image 4.32

5. The battery

The products of Metazet can contain two types of batteries, either Lead Acid batteries or Lithium-ion batteries. The properties of these batteries differ, and so does the handling of the batteries in your product.

 **Lifespan:** The lifespan of the battery is related to the number of charge cycles. For a Lithium-ion battery, the number of charge cycles, with correct usage, can be up to 10 times more than that of a Lead Acid battery. To achieve the specified lifespan for both types, it's essential to follow the instructions. Deviating from these instructions will result in a shortened lifespan of the batteries in your product.

Discharging: Discharging of batteries occurs when your product draws power from the batteries. Discharging happens even when your product is not in use. Therefore, it's crucial not to store the product when empty, as deeply discharging a battery leads to permanent damage. This cannot be repaired and results in a shortened lifespan.

1. Use your product in temperatures between 0 and 45 degrees Celsius.
2. Always switch off your product after use using the key switch.
3. Use your product until it reaches a certain State of Charge (SOC).
 - a. Lead Acid: Stop at an SOC between 30 and 50% (3-5 LEDs/blocks on the indicator).
 - b. Lithium-ion: Stop at an SOC between 10 and 20% (1-2 LEDs/blocks on the indicator).

Charging: Charging of the batteries involves the charger delivering power to the batteries. It's important that this is done correctly. Always charge your product when it reaches the minimum SOC values for your battery or before your product goes into long-term storage.

1. Only use the charger approved by Metazet to charge your product.
2. Use the charger only in temperatures between 0 and 30 degrees Celsius.
3. Use the charger within the following SOC range.
 - Lead Acid: Charging can be done at an SOC between 30 and 70% (3-7 LEDs/blocks on the indicator).
 - Lithium-ion: Charging can be done at an SOC between 10 and 100% (1-10 LEDs/blocks on the indicator).
4. Do not interrupt the charging process before the charger is ready.
 - Lead Acid: Applies to every charging cycle.
 - Lithium-ion: Applies to at least one charging cycle per week.
5. For long-term storage or no use (more than one month), charge your product fully and check intermittently if charging is needed.

It is essential to closely monitor the SOC of your product and take action accordingly. Failing to do so will have consequences for the lifespan of the batteries and therefore your product.

6. Battery charger

Metazet products come with a battery charger included, allowing you to charge your product with the appropriate charging curve. Since the curve for Lead Acid and Lithium-ion batteries differs, the battery chargers have different connectors. The Lead Acid battery is equipped with an XLR connector, and the Lithium-ion battery has a Speakon connector.

6.1 Charging Lead Acid Battery (XLR)

1. Park your product in a safe location.
2. Connect the XLR plug of the charger to your product (*Image 6.1*).
3. Plug the charger into the mains power. The charger can be used for 110 - 230 Volts. The charger automatically switches to the correct input voltage.
4. Once the charger is connected, it starts charging, and LEDs on the charger will light up. For all LED codes of the charger, refer to Table 6.1.
5. Disconnect the charger from the mains power and your product when it is fully charged (*Image 6.2*).

 To remove the charger plug: press the button first. Never pull on the cable; always pull on the plug (*Image 6.2*).



Image 6.1 – connecting battery charger



Image 6.2 – disconnecting battery charger

6.2 Charging Lithium-ion Battery (Speakon)

1. Park your product in a safe location.
2. Connect the Speakon plug of the charger to your product (*Image 6.3*).
3. Plug the charger into the mains power. The charger can be used for 110 - 230 Volts. The charger automatically switches to the correct input voltage.
4. Once the charger is connected, it starts charging, and LEDs on the charger will light up. For all LED codes of the charger, refer to *Table 6.1*.
5. Disconnect the charger from the mains power and from your product when it is fully charged. Disconnection may be done earlier, but it is important to charge up to 100% once a week (*Image 6.4*).

 **Speakon:** To remove the charger plug: slide the button backwards (1) and rotate the plug a quarter turn to the left (2), then pull the plug out of your product (*Image 6.4*). Never pull on the cable; always pull on the plug.

 **Lithium-ion charging:** You must reset the charger before charging a lithium-ion battery by removing the power cable from the socket and plugging it back in.



Image 6.3 – connecting battery charger

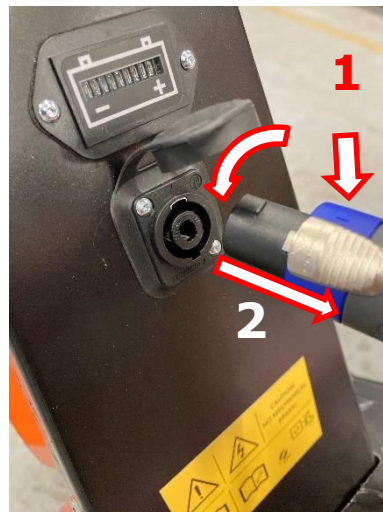

Image 6.4 – disconnecting battery charger

6.3 Information battery charger

6.3.1 LED-codes battery charger



Image 6.5 – Battery charger

LED Display codes battery charger					
Operational status during the charging process					Comment
Deep discharge start	Flashes				
Main charge	X				
Recharge		X			
End charging process / trickle charging			X		
Operational status in case of malfunction					Error number
Battery is missing				X	1
Battery error	Flashes			X	2
Time error	X			X	3-4
Control time		X		X	10-14
Temperature error			X	X	6
Resolving problems					
Error number	Procedure				
1,2,3,4	Check the battery and wiring				
6,11-13	Check the charger				

Table 6.1

6.3.2 Comments:

- The charger has a built-in protection that prevents overcharging of the batteries. There is no need to remove the charger immediately after charging.
- As long as the charger is connected to the mains cable, your product cannot be moved. Remove all connections to the charger before using the product.

6.3.2.1 Charging with charger



Charging the batteries must be done in a room that has sufficient ventilation. It is the customer's own responsibility to use a loading space that meets the requirements.



The charger can remain connected (switched on) to the battery pack until your product is used again.



If your product is not used for an extended period of time, ensure that your product is charged once a month. To do this, disconnect the charger from the 110-230 V and reconnect it. Charger automatically starts a new charging cycle. This way you keep your batteries in good condition.



Charging multiple batteries or battery packs in succession:

The battery chargers must first be reset when charging multiple battery packs in succession. This can be done by switching the battery charger off and on again.



There are also a number of points that you should pay attention to with the battery charger:

- Do not drop the battery case, battery(s) or battery charger.
- Charge the battery(ies) in a well-ventilated area.
- Do not expose the battery(ies) to heat or direct sunlight.
- The batteries may only be charged at a temperature between 15-25°C.
- Prevent water from coming into contact with the battery(s) or battery charger.
- NEVER cover the battery charger.

7. Maintenance

Maintain your product regularly. Regular checks prevent accidents. Maintenance of the batteries and the electrical system may only be carried out by certified persons, with all necessary safety equipment.



WARNING: Always turn off your product before beginning maintenance

7.1 General maintenance

7.1.1 Maintenance every month:

- All bolted connections: ensure that all bolted connections are secure.
- Cleaning: clean your product every month, NOT with water or high-pressure spray.
- Do not remove any parts during removal.
- Do not use flammable products for contamination.
- Charging, charge your product once a month when you are not using it.

7.1.2 Maintenance every 3 months:

Wheel maintenance

- Check the wheels for damage.
- Check the tires for wear. Replace the tires if the tread depth is less than 2 mm.
- Adjust the tire pressure of the wheels again.

7.1.3 Maintenance every 6 months:

- Electrical system maintenance
- Check all connections. Replace damaged wires and connections.
- Also check the fuses. These are located under the control panel.
- Check the carbon brushes of the electric motor (with the exception of TRIKE 3000 and E-Nova):



Image 7.1 – carbon brush



WARNING: Before servicing the electrical system, disconnect the batteries from your product or turn off the fuse on the control panel.

8. Error codes

8.1 Error codes LED battery indicator

LED-codes batterij-indicator	
Indicator flashes slowly	Battery voltage low, charge batteries as soon as possible.
Indicator flashes every 5 seconds	The controller has entered sleep mode, reset your product by turning the key again.
Indicator flashes quickly	Your product is in error mode, see table 10.2 for the error codes.

Table 8.1

LED-codes batterij-indicator - knippert snel	
I	The battery needs to be charged, there is a poor connection to the battery or the battery lock function is active and the controller is in a limited operating mode. Check the connections to the battery. If the connections are good, try charging the battery.
II	There is a bad connection to the motor. Check all connections between the motor and the controller.
III	The motor has a short circuit with a battery connection. Contact your service agent.
IIII	The motor has a short circuit with a battery connection. Contact your service agent.
IIIII	The battery charge level has dropped below the battery lock level and the controller is preventing certain machine functions. Charge the batteries.
IIIIII	The steering is no longer activated, possibly due to an emergency stop. Restart your product.
IIIIIII	A roadway disruption has been indicated. Make sure the throttle is in the neutral position before turning on your product.
IIIIIIII	An error has been indicated in the controller. Make sure all connections are properly connected.
IIIIIIIII	Too high voltage has been applied to the controller. This is usually caused by a bad battery connection. Check the battery connections.

Table 8.2

8.2 Error codes LCD battery indicator





























Code / LED Flashes	Sigmagauge Icon	Cause / Action
Warning Error		
0 / On		Controller is functioning.
1		Handbrake switch closed. Release Handbrake.
2		Battery voltage 'becoming' too low. Charge battery or check its condition and connections.
3		Not used
4		Battery voltage 'becoming' too high. Reduce braking levels or vehicle speed.
5		Thermal foldback. Allow motor to cool, operate vehicle within specification.
6		Controller over-temperature. Allow controller to cool and check drive train.
7		Out-of-Range programming. Check all parameters are within permitted limits.
8		Default settings restored after re-flash. Cycle power.
Main Error – Recycle to Neutral		
9		Internal memory error. Contact Service Agent.
10		Direction selection error – both Fwd and Rev selected. Check direction switch operation and connections.
11		Seat or Tiller switch not closed. Check switch operation and connections.
12		Sequence error – the Footswitch or Direction switch is operated at power-up. Check switch operation and connections.
13		Accelerator deflected at power-up. Check Accelerator operation and connections.
14		Ride-on – forbidden input selected (Fwd, Rev, FS, Seat, Handbrake), when inching the vehicle. Walkie – drive is attempted without releasing the belly switch after time-out period has passed.
15		Internal 12 V supply too low. Check peripherals and battery.
16		Not used
17		Battery voltage too low. Charge battery or check its condition an connections.
18		High-side MOSFET error in neutral or while pulsing. Check motor insulation and line contractor. If error persists, contact Service Agent.
19		Low-side MOSFET error while pulsing. Check motor insulation. If error persists, contact Service Agent.
Hard Error – Recycle Key-switch		
20		Motor over current. Check programming of motor parameters.
21		Contact coil error. Check contractor coil(s) and connections.
22		Battery voltage too high. Reduce braking levels or speed.
23		Low-side MOSFET error in neutral. Check motor insulation and line contactor. If error persists, contact Service Agent.
24		Controller error or line contactor coil error. Check line contactor coil. If error persists, contact Service Agent.
25		Contactor error. Check coil(s) & contacts.
26		Controller error. Contact Service Agent.
27		Low-side MOSFET error before line contactor has closed. Check motor insulation and line contactor. If error persists, contact Service Agent.
28		Wig-Wag wire of detected. Check pot. Wiring on Connector A pins 8, 9, and 16.
29		CAN error. A CAN node is not responding. Check all nodes and their connections.
30		Over-speed or encoder error. Check encoder programming value 4.3 Number of Teeth and ensure that 4.8 Motor Speed Maximum is higher than 1.4 Maximum Forward Speed and 1.5 Maximum Reverse Speed.

Table 8.3

9. Parts & Service

To order parts or register Service, you can scan the QR code applied to your product, or go to the website www.metazet.com and click on the "Parts & Service" button

10. Quick manual

You will find the quick manual enclosed with your product. This gives the user the most important information about the product. This manual is not a replacement for the manual and does not guarantee safe use. The original manual is the only document that complies with all regulations. In case of conflicting information, it is always the manual that contains the correct information.

Trike-400

Trike-1200

Trike-3000s

E-Nova

H-400

H-400 XL

HT-1500

11. Resolving problems



Always check battery indicator error codes (*Table 11.1*)

Problem	Cause	Solution
Your product does not start	The ignition lock is not turned on.	Insert the key in the ignition lock, turn right. Check the fuses in your product.
	One or more fuses have blown	Check the wiring for damage and defective connections. Replace if broken.
	The wiring is damaged or not connected correctly	Replace damaged wires Charge batteries or replace them
	Empty battery	Always check the error codes of the battery indicator (<i>table 10.2</i>)
Your product starts, but does not drive	Controller error	Check chapter 'Error codes'
	The battery charger is connected	Disconnect the battery charger
	The emergency stop/ button is active	Check if the emergency stop/ button is inactive, and put it on active
	The foot pedal is not pressed	Press the foot pedal
Your product rattles while driving	A bolt has come loose	Tighten the bolt securely
The steering wheel is loose	A bolt has come loose	Tighten the bolt securely
The batteries are not charging	The battery charger is not connected	Connect the battery charger correctly
	The fuse of the battery charger is broken	Replace the fuse
	The wiring is damaged or not connected correctly.	Check the wiring for damage and defective connections.
	The XLR plug is broken	Replace damaged wires. Check all 3 pins of the connector in your product.
Your product drives jerkily	The wiring is damaged or not connected correctly	Check the wiring for damage and defective connections. Replace damaged wires.
	The carbon brushes are worn out.	Replace the carbon brushes.
The charger cannot be disconnected from your product	The connection is secured.	Push the button while you disconnect the charger.
Your product is accelerating too quickly	There is a problem with the controller	Contact the manufacturer
Uw product rijdt langzaam (kruipsnelheid)	Empty battery	Charge and move if necessary by putting it in free mode.
	Lithium-ion connector: connections are not secure	Check the connections on the connector

Tabel 11.1

12. Machine

12.1 Technical specifications Trike 400

Manufacturer	Metazet B.V.
Driver	Transaxle
Max. bodyweight driver	125 Kg
Carrying load	40 Kg
Nominal pulling force	52,3 N
Towing weight	250 Kg (According to VDI 2198)
Weight	135 Kg
Material	Steel
After-treatment	Powder coating
Max. speed forward (turtle)	7 Km/h
Max. speed forward (hare)	10 Km/h
Max. speed backwards (turtle)	3 Km/h
Max. speed backwards (hare)	4 Km/h
Time to reach max. speed	5 s
Motor type	Permanent magnet motor
Power	400 W
Battery type	AGM or Lithium
Battery voltage	24V (2x 12V) or 24V
Battery capacity AGM	45 Ah/C20 , 40 Ah/C5
Battery capacity Lithium (optional)	40 Ah/C5
Battery weight	2x 15,1 Kg , 11 Kg
Battery charger	110/230V, 50-60 Hz. 24V, 8A.
Control	Programmable I-Drive 70A

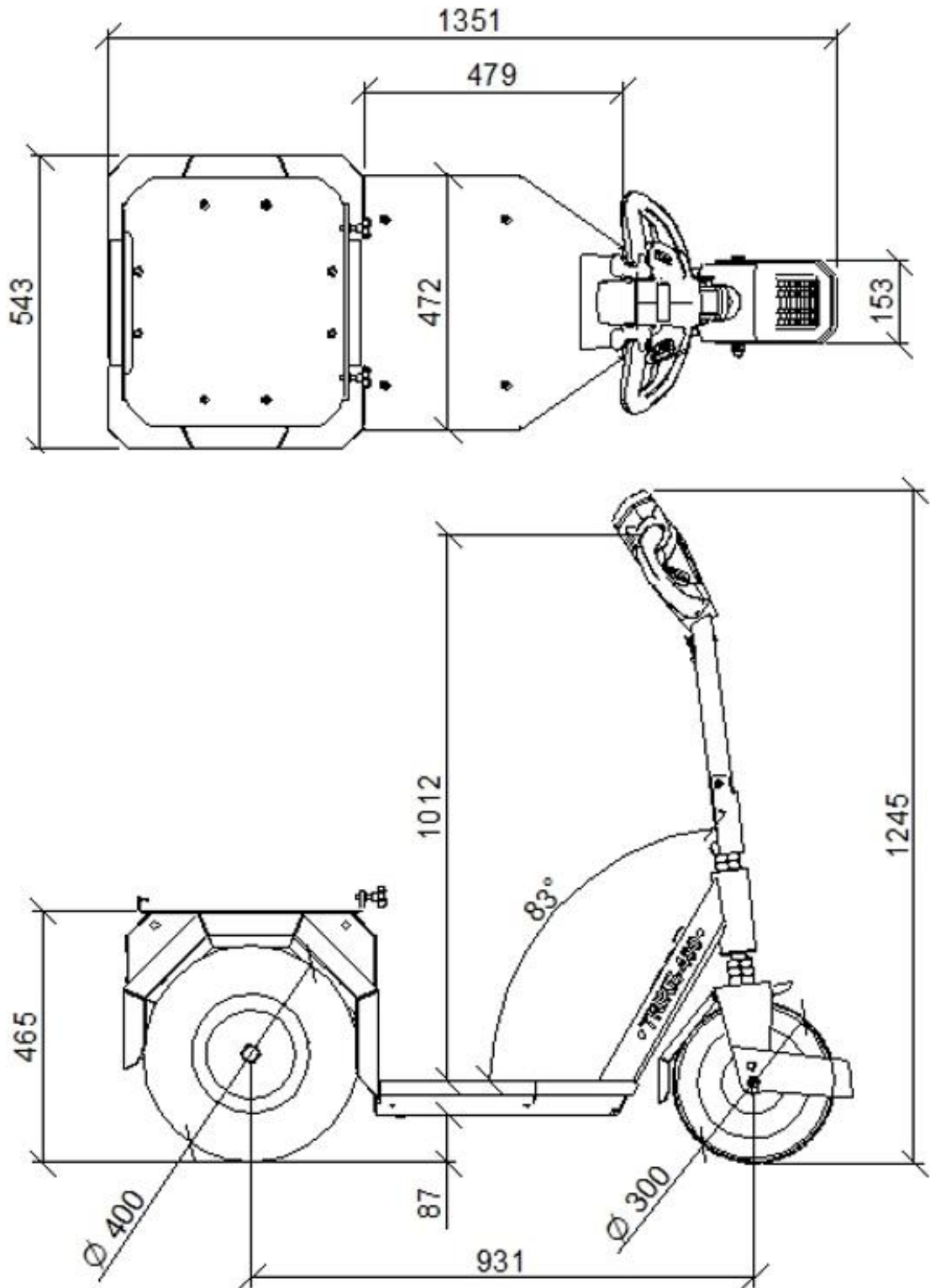

Measurements Trike 400

12.2 Technical specifications Trike 1200

Manufacturer	Metazet B.V.
Driver	Transaxle
Max. bodyweight driver	125 Kg
Carrying load	40 Kg
Nominal pulling force	400 N
Towing weight	1600 Kg (According to VDI 2198)
Weight	200 Kg
Material	Steel
After-treatment	Powder coating
Max. speed forward (turtle)	7 Km/h
Max. speed forward (hare)	8 Km/h
Max. speed backwards (turtle)	5 Km/h
Max. speed backwards (hare)	6 Km/h
Time to reach max speed	4 s
Motor type	Permanent magnet motor
Power	800 W
Battery type	AGM, Lithium
Battery voltage	24V (2x 12V), 24V
Battery capacity AGM	100 Ah/C20
Battery capacity Lithium (optional)	70 Ah/C5
Battery weight	2x 33 Kg or 18.6 Kg
Battery charger	110/230V - 24V/12A XLR of SpeakON
Control	Programmable I-Drive 140A

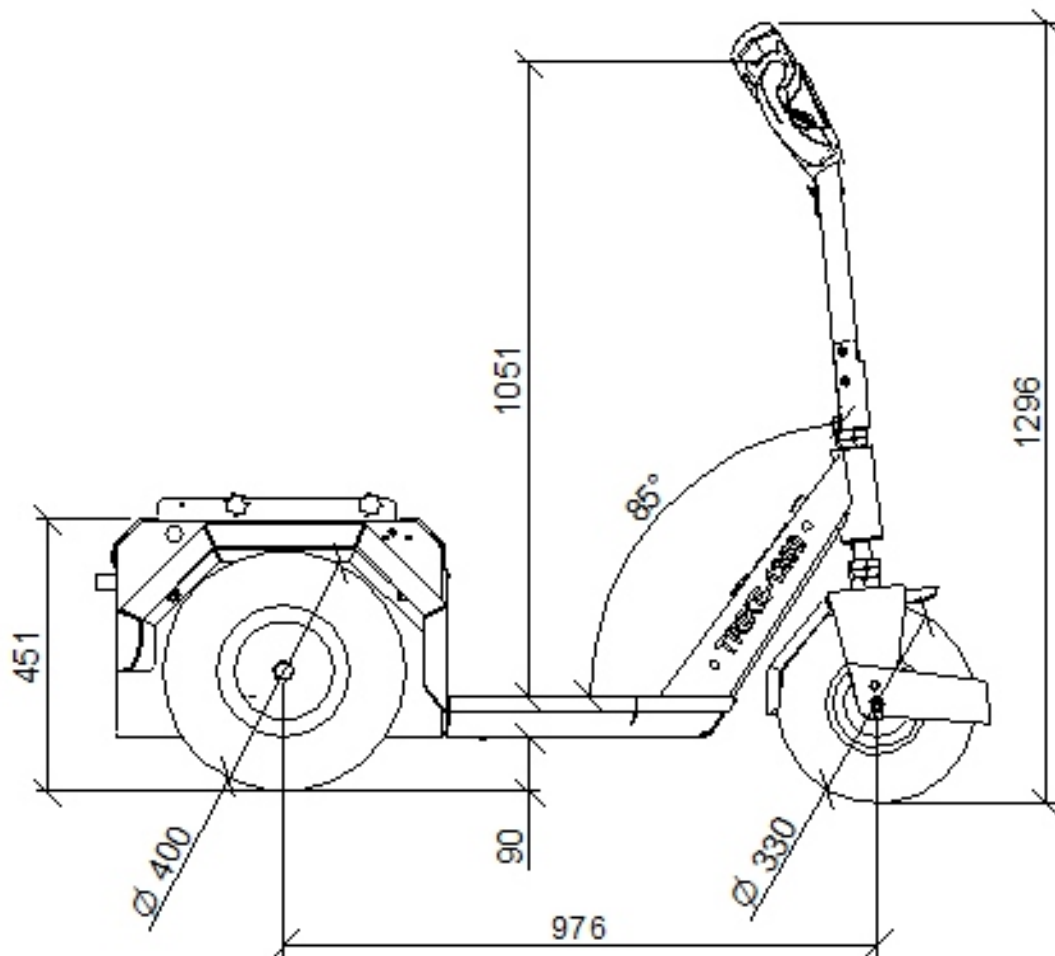
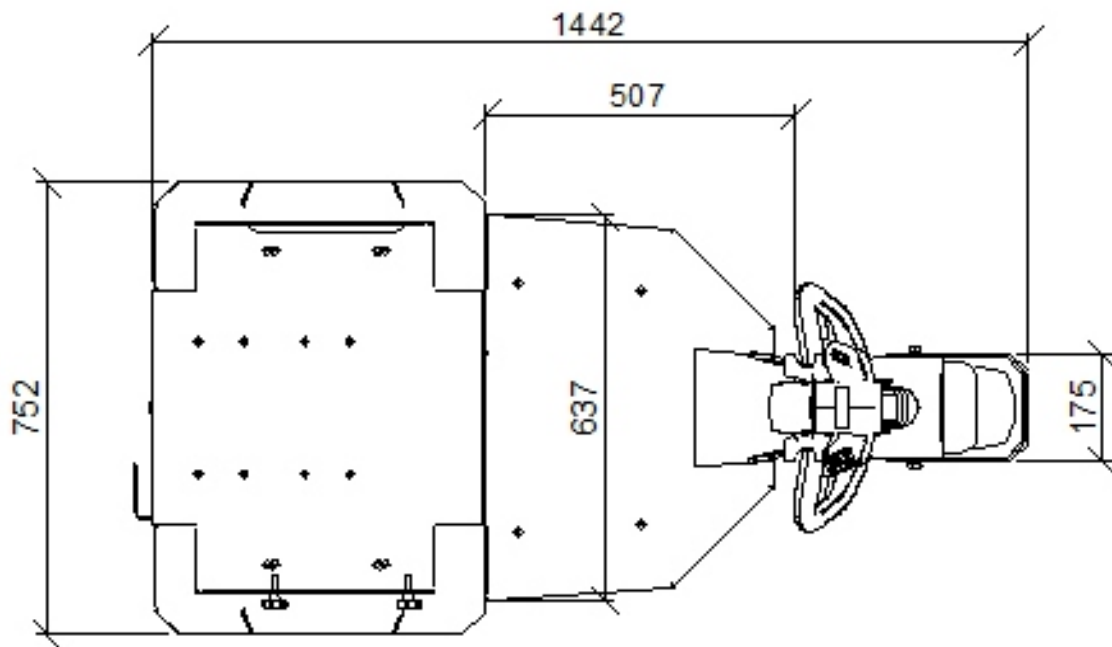

Measurements Trike 1200

12.3 Technical specifications Trike 3000s

Manufacturer	Metazet B.V.
Driver	Transaxle
Max. bodyweight driver	125 Kg
Carrying load	40 Kg
Nominal pulling force	1080 N
Towing weight	3500 kg (According to VDI 2198)
Weight	325 Kg
Material	Steel
After-treatment	Powder coating
Max. speed forward (turtle)	7 km/h
Max. speed forward (hare)	12 Km/h
Max. speed backwards	7 km/h
Time to reach max speed	2,5 s
Motor type	Asynchronous motor
Power	1500 W
Battery type	AGM or Lithium
Battery voltage	24V (2x 12V), 24V
Battery capacity	100 Ah/C20
Battery capacity Lithium (optional)	70 Ah/C5
Battery weight	2x 35 Kg or 18.6 Kg
Battery charger	110/230V - 24V/12A/XLR or SpeakON
Control	Programmable Sigmadrive 180A

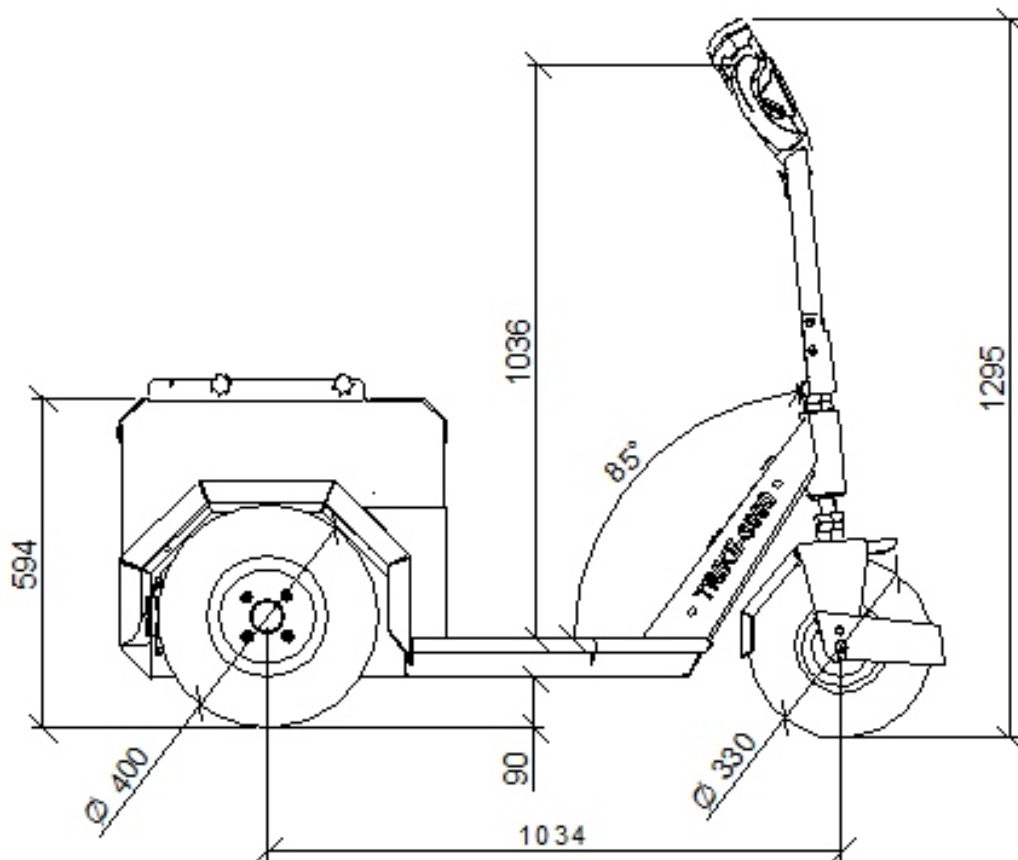
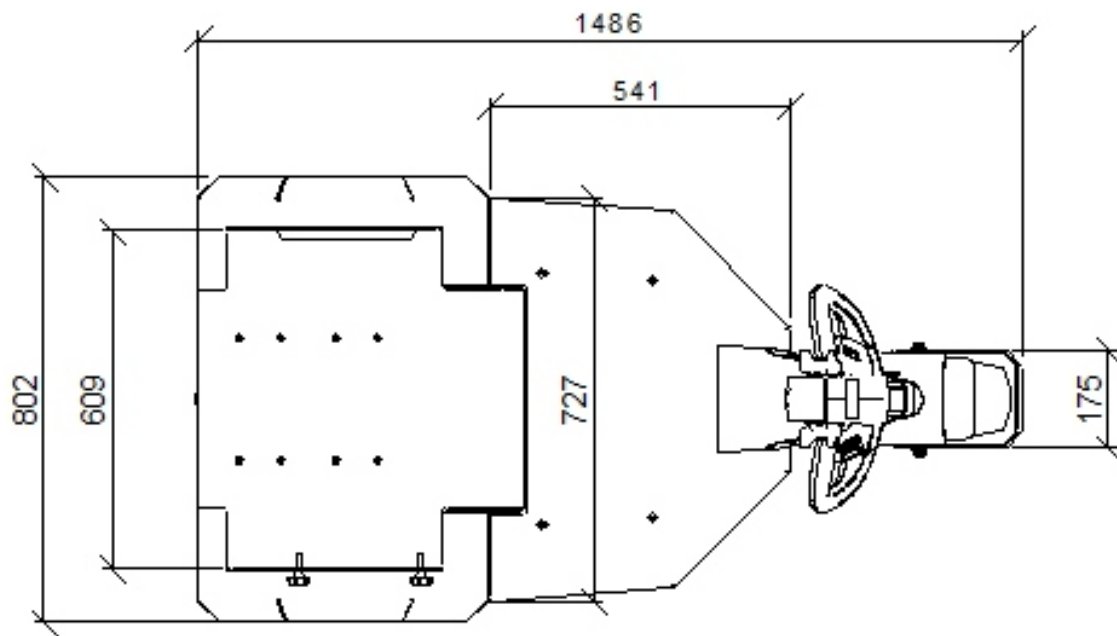

Measurements Trike 3000

Trike-400

Trike-1200

Trike-3000S

E-Nova

H-400

HT-400 XL

HT-1500

12.4 Technical specifications E-Nova

Manufacturer	Metazet B.V.
Maximum load	125 Kg
Weight E-Nova (without battery pack)	250 Kg
Weight battery pack AGM	75 Kg
Weight battery pack Lithium 70A	26 Kg
Weight battery pack Lithium 140A	44 Kg
Max. speed forward (turtle)	7 Km/h
Max. speed forward (hare)	12 Km/h
Max. speed backwards	7 km/h
Max. pulling power	2500 kg (According to VDI 2198)
Turning circle	2050 mm
Driver	Transaxle
Power	1500W AC
Battery type	AGM or Lithium
Battery voltage	24 V
Capacity AGM battery	100 Ah/C20
Capacity Lithium 70AH	70 Ah/C5
Capacity Lithium 140Ah	140 Ah/C5
Weight	2x 35 Kg or (2x) 18.6 kg
Standard charger properties	110/ 230V, 50-60 Hz, 24V - 12A
Control	Programmable C3 controller 200A/24V

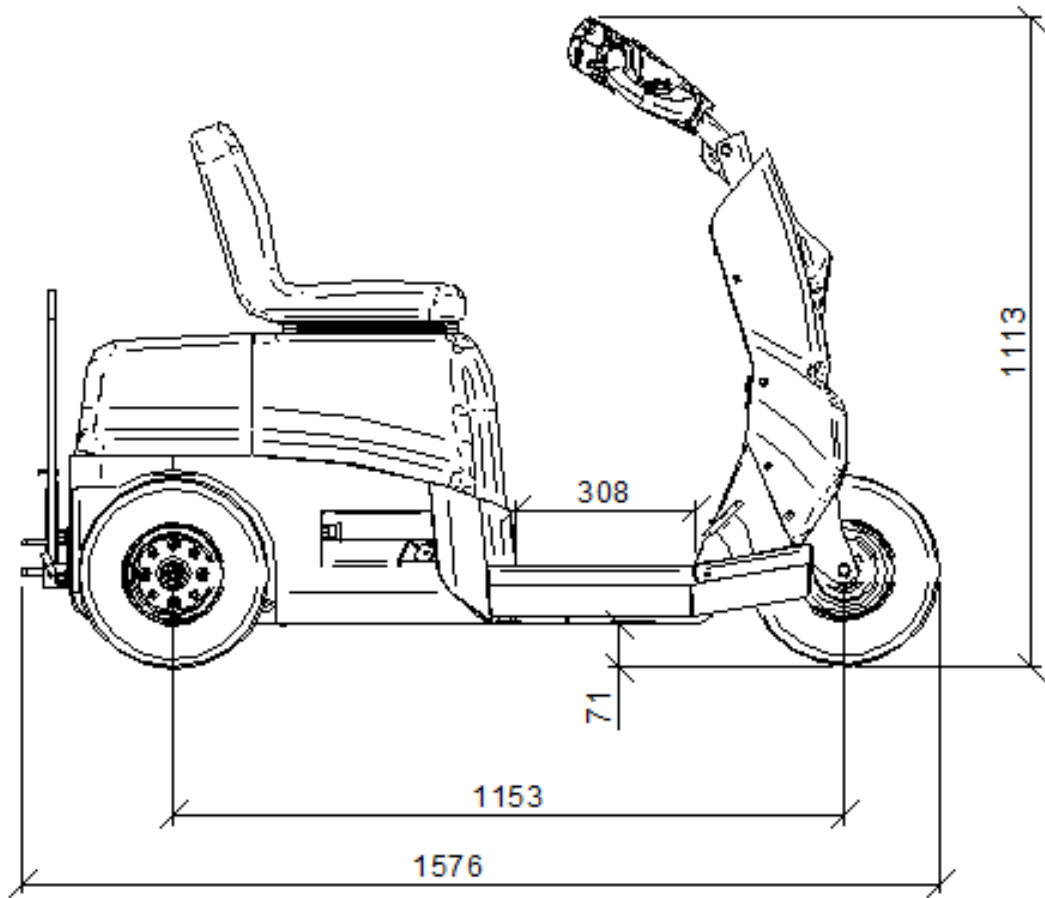
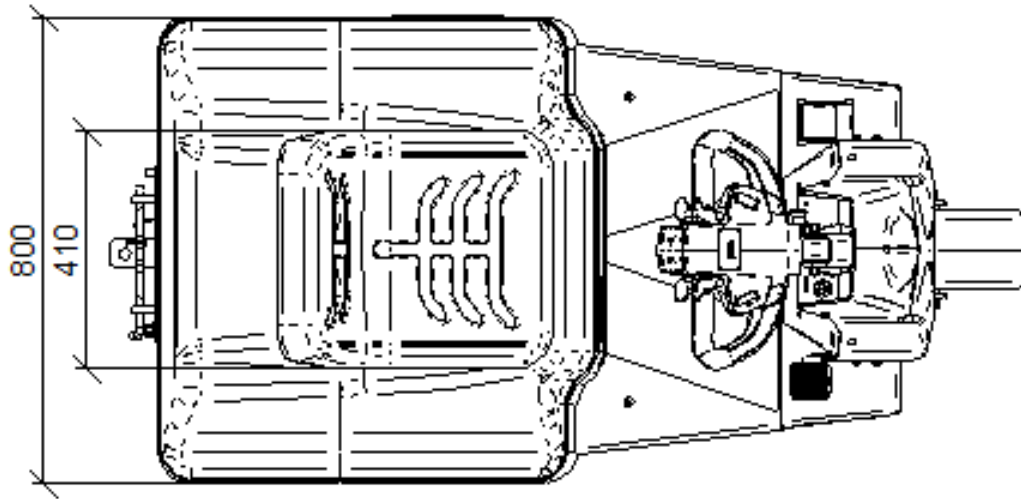

Measurements E-Nova

Trike-400

Trike-1200

Trike-3000s

E-Nova

H-400

HT-400 XL

HT-1500

12.5 Technical specifications H-400

Manufacturer	Metazet B.V.
Driver	Transaxle
Nominal pulling force	157 N
Towing weight	1000 Kg (According to VDI 2198)
Weight	90 Kg
Material	Steel
After-treatment	Powder coating
Max. speed forward (turtle)	3 Km/h
Max. speed forward (hare)	6 Km/h
Max. speed backwards (turtle)	3 Km/h
Max. speed backwards (hare)	6 Km/h
Time to reach max speed	5 s
Motor type	Permanent magnet motor
Power	400 W
Battery type	AGM or Lithium
Battery voltage	24V (2x 12V) or 24V
Battery capacity AGM	45 Ah/C20
Battery capacity Lithium	40 Ah/C5
Battery weight	2x 15,1 Kg or 11 kg
Battery charger	230V, 50-60 Hz. 24V, 8A.
Control	Programmable I-Drive 70A

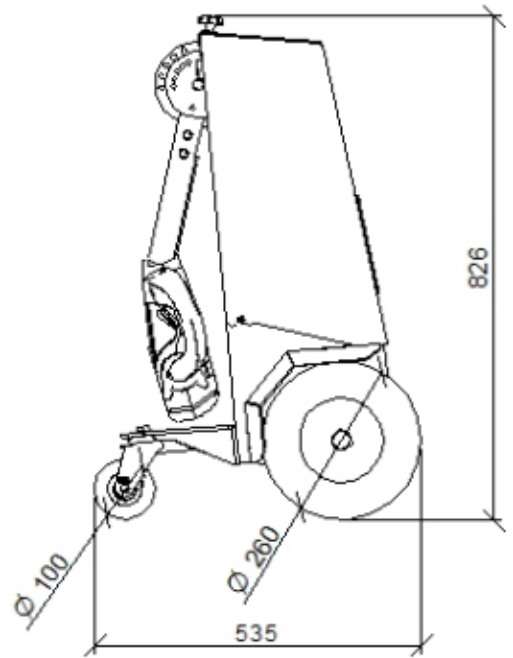
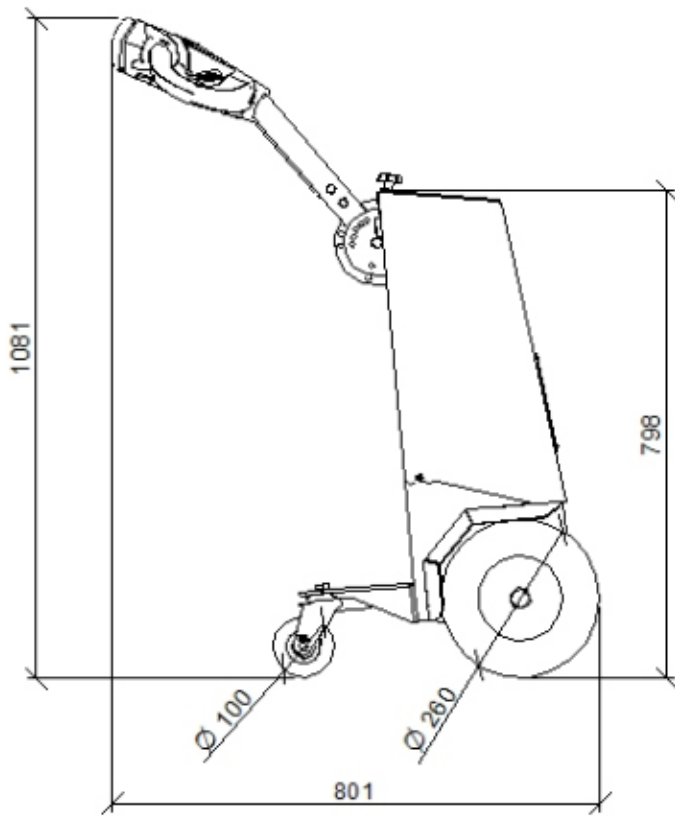
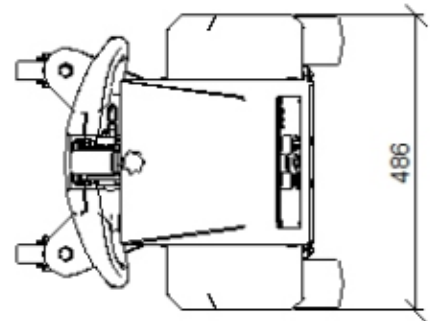
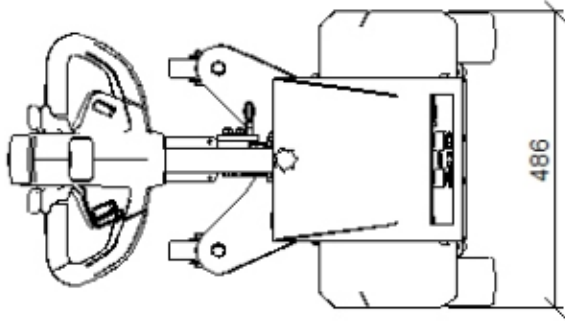

Measurements H-400

Trike-400

Trike-1200

Trike-3000s

E-Nova

H-400

HT-400 XL

HT-1500

12.6 Technical specifications HT-400 XL

Manufacturer	Metazet B.V.
Driver	Transaxle
Carrying load	600 Kg (evenly distributed)
Weight	210 Kg
Material	Steel
After-treatment	Powder coating
Max. speed forward (turtle)	3 Km/h
Max. speed forward (hare)	6 Km/h
Max. speed backwards (turtle)	3 Km/h
Max. speed backwards (hare)	6 Km/h
Time to reach max speed	5 s
Motor type	Permanent magnet motor
Power	400 W
Battery type	AGM or Lithium
Battery voltage	24V (2x 12V) or 24V
Battery capacity	45 Ah/C20
Battery capacity Lithium	40 Ah/C5
Battery weight	2x 15,1 Kg or 11 Kg
Battery charger	230V, 50-60 Hz. 24V, 8A.
Control	Programmable I-Drive 70A

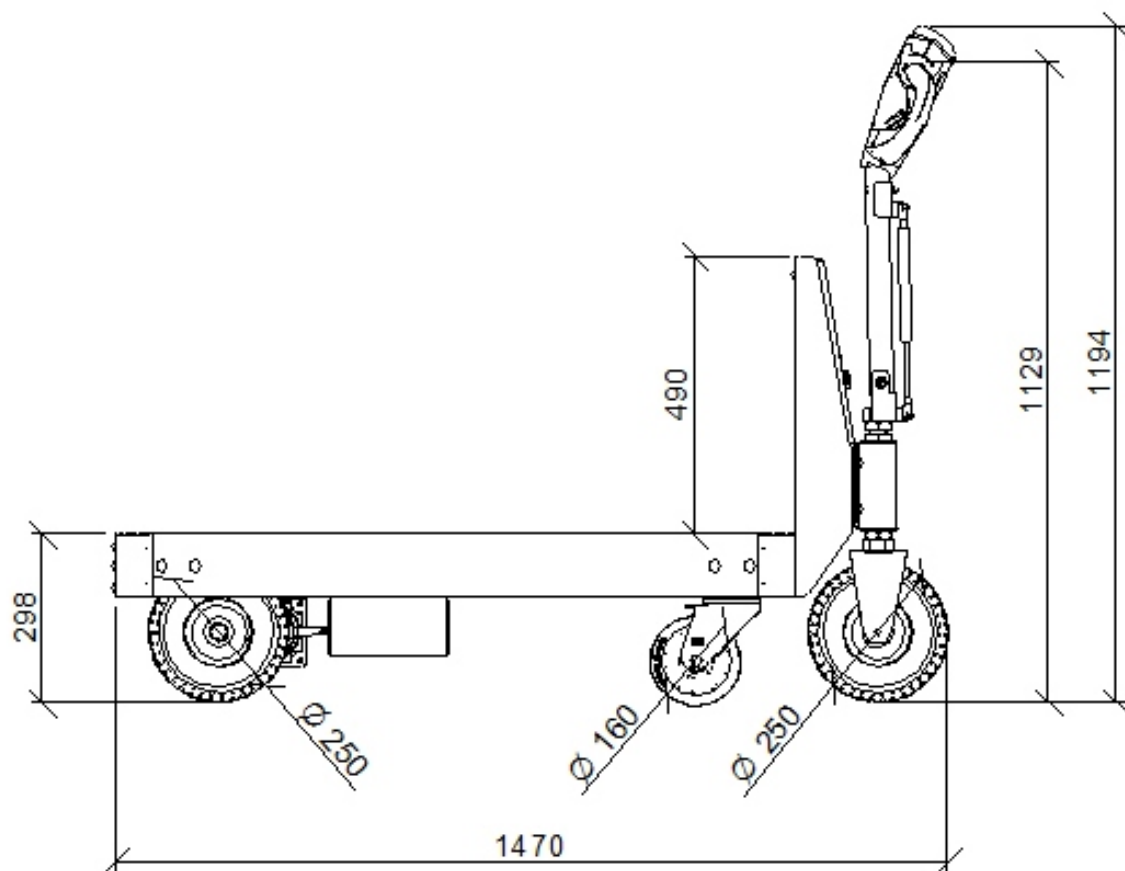
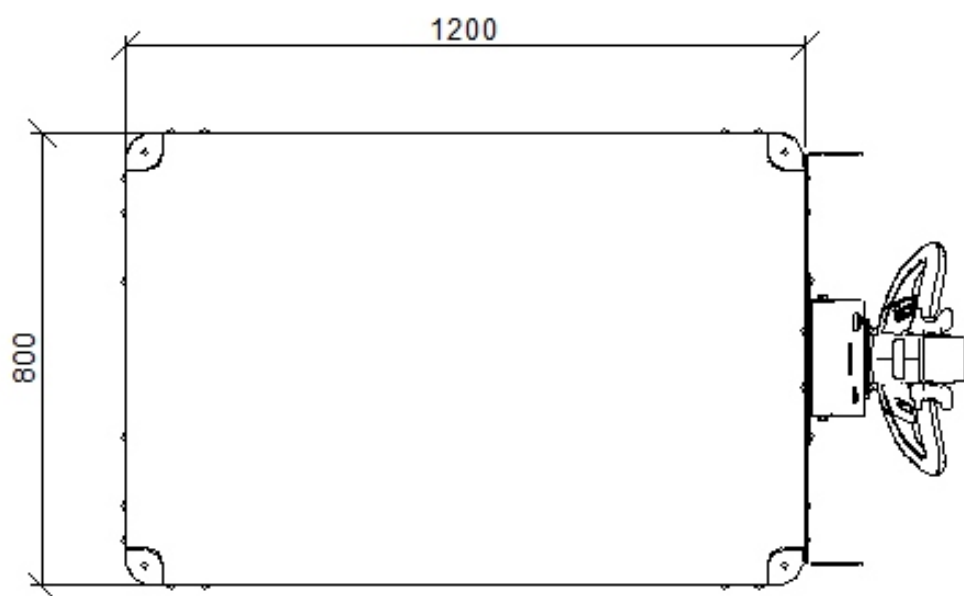

Measurements HT-400 XL

12.7 Technical specifications HT-1500

Manufacturer	Metazet B.V.
Driver	Transaxle
Carrying load	600 Kg (evenly distributed)
Weight	210 Kg
Material	Steel
After-treatment	Powder coating
Max. speed forward (turtle)	3 Km/h
Max. speed forward (hare)	6 Km/h
Max. speed backwards (turtle)	3 Km/h
Max. speed backwards (hare)	6 Km/h
Time to reach max speed	5 s
Motor type	Permanent magnet motor
Power	400 W
Battery type	AGM or Lithium
Battery voltage	24V (2x 12V) or 24V
Battery capacity	45 Ah/C20
Battery capacity Lithium	40 Ah/C5
Battery weight	2x 15,1 Kg or 11 Kg
Battery charger	230V, 50-60 Hz. 24V, 8A.
Control	Programmable I-Drive 70A

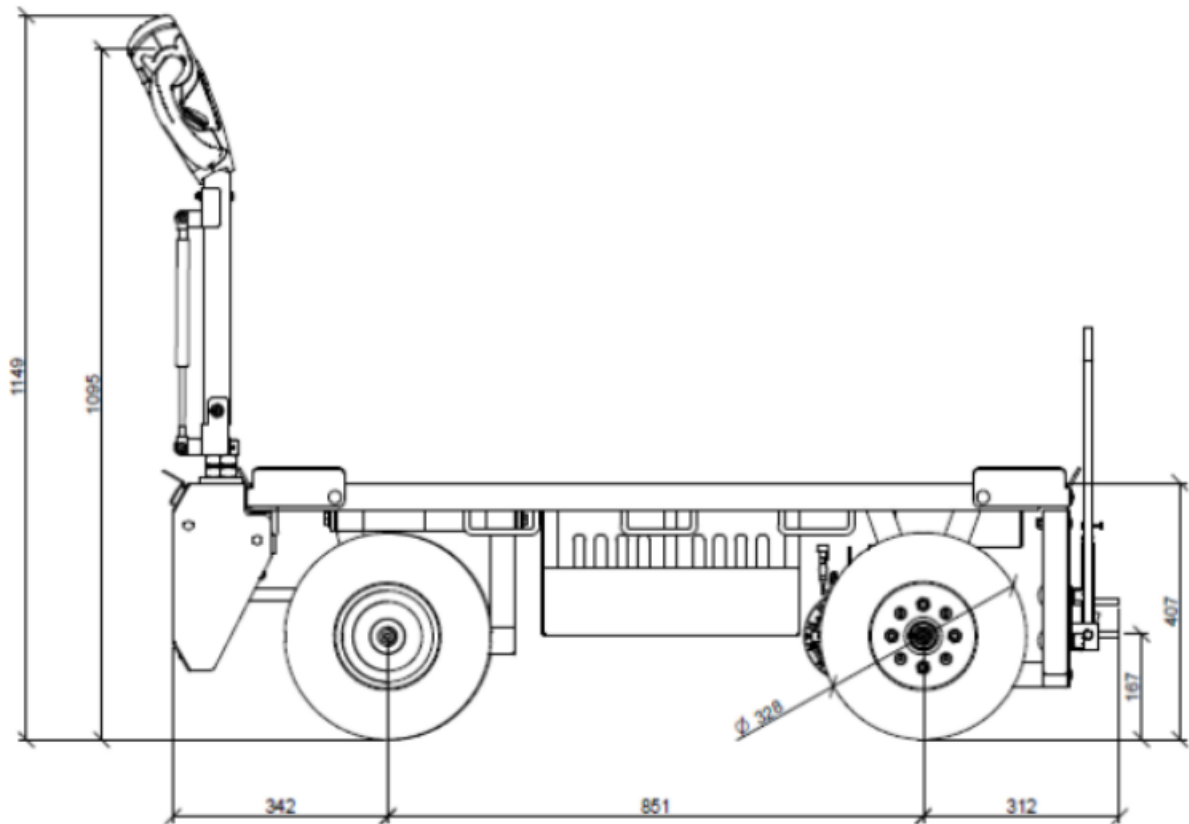
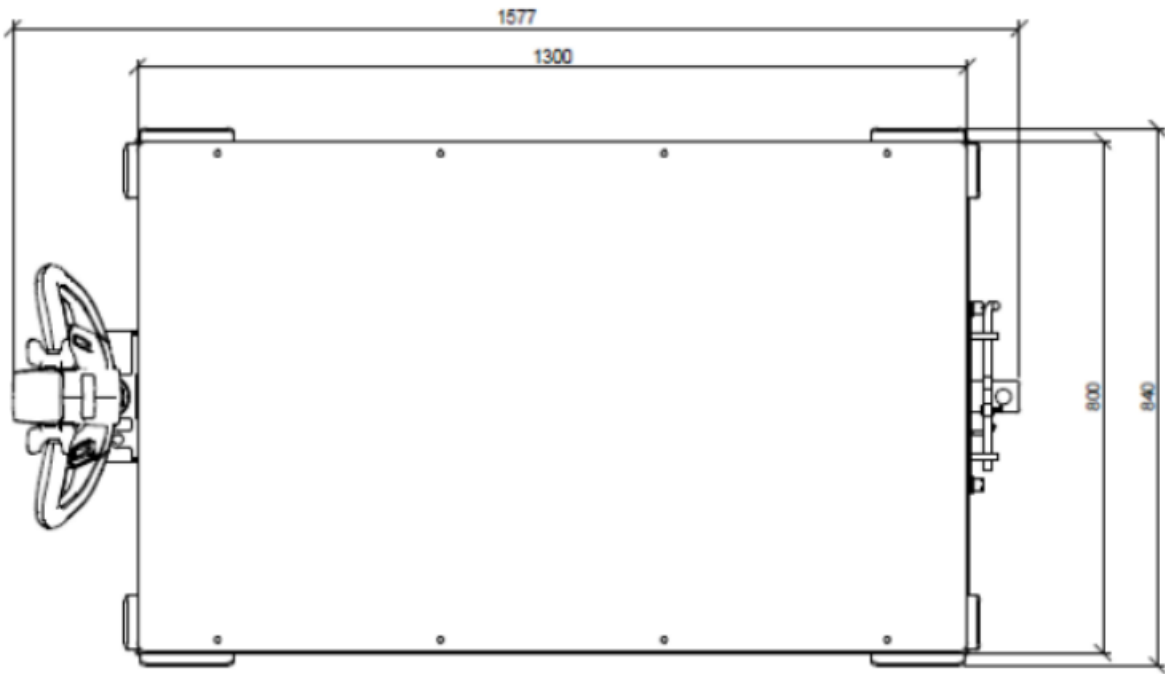

Measurements HT-1500

12.8 Type plate

Each product has its own type plate:

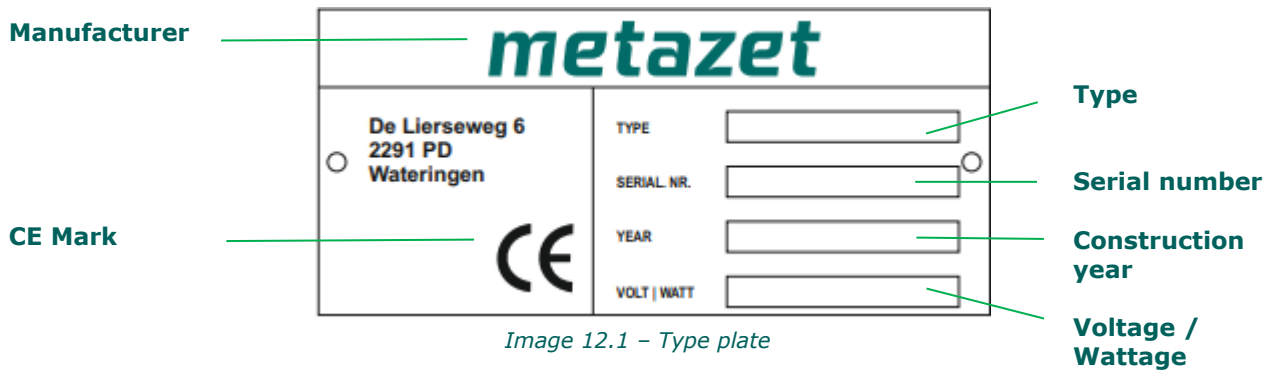

Image 12.1 - Type plate